

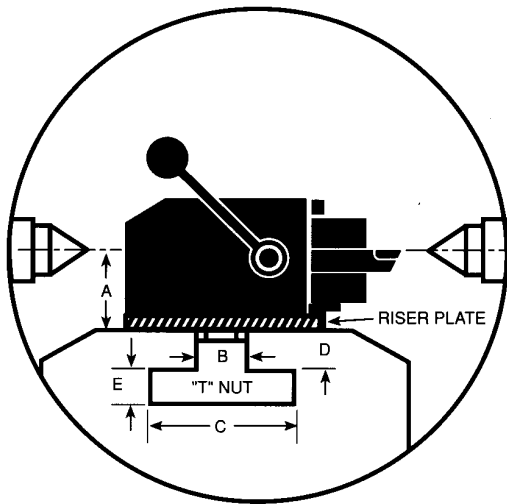

**DIMENSIONS NEEDED TO FIT KDK TOOL POSTS TO YOUR LATHE**

KDK tool posts usually require a riser plate between the tool post and lathe compound to bring tool to lathe center height. A riser plate, up to 1 1/8" thick, will be furnished FREE if you specify make and model of lathe or furnish lathe center height. See dimension 'A' below. Special riser plates thicker than 1 1/8" furnished at time and material.

NOTE: T-Nuts are not standard for all lathes. To insure correct size, furnish T-Slot dimensions B, C, D, and E (see drawing below), and specify make and model of lathe.



**Make of Lathe:** \_\_\_\_\_

**Model of Lathe:** \_\_\_\_\_

**Please provide the following dimensions:**

For Free Riser Plate **A:** \_\_\_\_\_

For Machined T-Nut **B:** \_\_\_\_\_

(extra charge applies) **C:** \_\_\_\_\_

**D:** \_\_\_\_\_

**E:** \_\_\_\_\_

**Company Name:** \_\_\_\_\_

**Address:** \_\_\_\_\_

**City:** \_\_\_\_\_ **State:** \_\_\_\_\_ **Zip Code:** \_\_\_\_\_

**Contact:** \_\_\_\_\_

**Phone Number:** \_\_\_\_\_ **Fax Number:** \_\_\_\_\_

**E-Mail Address:** \_\_\_\_\_

**Fax completed form to: (800) 779-8188 or (928) 556-3048**

For additional information, please visit our website at [www.kdktools.com](http://www.kdktools.com).